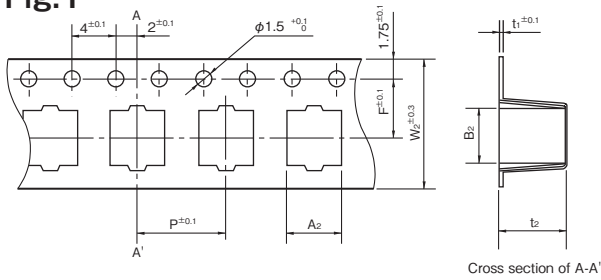
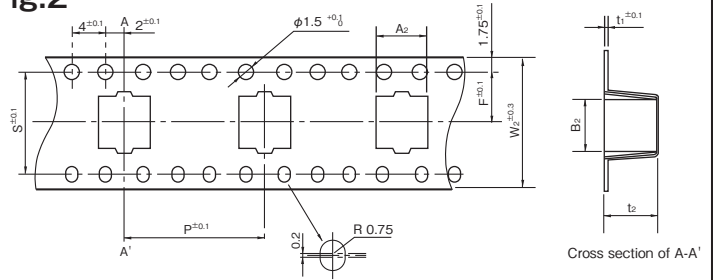
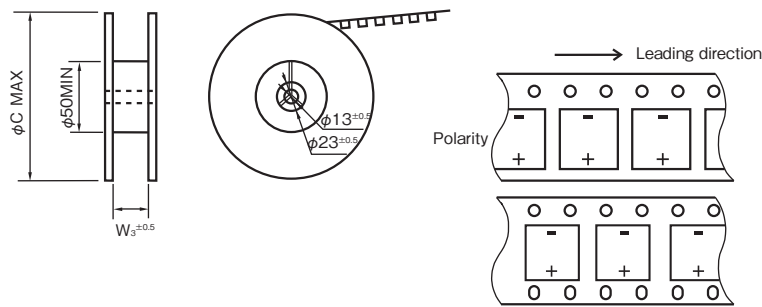

object : Chip type capacitors
◆TAPING DIMENSIONS
Fig.1

Fig.2

Size	W ₂ (mm)	A ₂ (mm)	B ₂ (mm)	P (mm)	t ₂ (mm)	F (mm)	t ₁ (mm)	S (mm)	Applicable
φ4×5.5	12.0	4.7	4.7	8	5.7	5.5	0.4	—	Fig.1
φ5×5.5	12.0	5.7	5.7	12	5.7	5.5	0.4	—	
φ6.3×5.5	16.0	7.0	7.0	12	5.7	7.5	0.4	—	
φ4×6.1	12.0	4.7	4.7	8	6.2	5.5	0.4	—	
φ5×6.1	12.0	5.7	5.7	12	6.2	5.5	0.4	—	
φ6.3×6.1	16.0	7.0	7.0	12	6.2	7.5	0.4	—	
φ6.3×8	16.0	7.0	7.0	12	8.2	7.5	0.4	—	
φ8×6.5	16.0	8.7	8.7	12	6.8	7.5	0.4	—	
φ8×10.5	24.0	8.7	8.7	16	11.0	11.5	0.4	—	Fig.2
φ10×10.5	24.0	10.7	10.7	16	11.0	11.5	0.4	—	
φ12.5×13.5	32.0	13.4	13.4	24	14.4	14.2	0.5	28.4	
φ12.5×16	32.0	13.4	13.4	24	16.3	14.2	0.5	28.4	
φ16×16.5	44.0	17.5	17.5	28	17.4	20.2	0.5	40.4	
φ16×21.5	44.0	17.5	17.5	28	22.4	20.2	0.5	40.4	
φ18×16.5	44.0	19.5	19.5	32	17.4	20.2	0.5	40.4	Fig.2
φ18×21.5	44.0	19.5	19.5	32	22.4	20.2	0.5	40.4	

◆TAPING REEL AND PACKING QUANTITY

Size	W ₃ (mm)	φC (mm)	Quantity/reel	Standard Shipping Carton Quantity
φ4×5.5,6.1	14	382	2,000	10,000
φ5×5.5,6.1	14	382	1,000	5,000
φ6.3×5.5,6.1	18	382	1,000	5,000
φ6.3×8	18	382	900	4,500
φ8×6.5	18	382	1,000	5,000
φ8×10.5	26	382	500	2,000
φ10×10.5	26	382	500	2,000
φ12.5×13.5	34	332	200	600
φ12.5×16	34	332	150	450
φ16×16.5,φ18×16.5	46	332	125	250
φ16×21.5,φ18×21.5	46	332	75	150

Reusable reels are available according to your request.
Please consult in regard to establishing supply and withdrawal system.

◆ LEAD FREE TYPE REFLOW SOLDERING CONDITION
● Size $\phi 4 \sim \phi 10$

- 1) Temperature at surface of capacitor shall not exceed $T^{\circ}\text{C}$.
- 2) Period that temperature at surface of capacitor becomes more than 200°C and $T_1^{\circ}\text{C}$ shall not exceed t and t_1 seconds, respectively.
- 3) Preheat shall be made at $100^{\circ}\text{C} \sim 200^{\circ}\text{C}$ and for maximum 180 seconds.

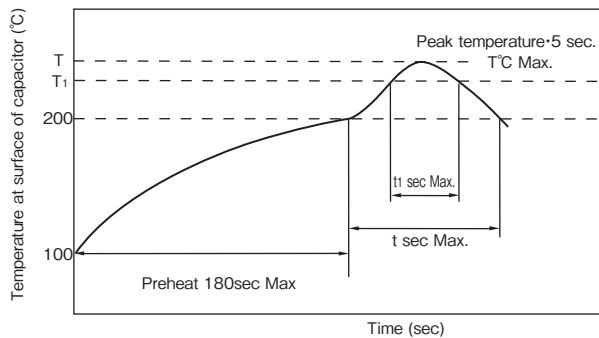

Series	Size	$T(^{\circ}\text{C})$ ①	$T_1(^{\circ}\text{C})$	$t(\text{sec})$ ②	$t_1(\text{sec})$ ③	Reflow cycle
SGV TZV TXV TLV	$\phi 4 \sim \phi 6.3$	250	230	90	40	1
THV TKV	$\phi 8$	240	230	90	30	1
SJV SLV	$\phi 4 \sim \phi 6.3$	240	220	60	40	1
JGV JZV	$\phi 4 \sim \phi 6.3$	260	217	—	60	2
	$\phi 8, \phi 10$	250	217	—	60	2

- ① Peak temperature
- ② Time more than 200°C
- ③ Time more than T_1

※ Please contact us if the condition is over the maximum.

◆ LEAD FREE TYPE REFLOW SOLDERING CONDITION
● Size $\phi 12.5 \sim \phi 18$

- 1) Temperature at surface of capacitor shall not exceed $T^{\circ}\text{C}$.
- 2) Period that temperature at surface of capacitor becomes more than 200°C and $T_1^{\circ}\text{C}$ shall not exceed t and t_1 seconds, respectively.
- 3) Preheat shall be made at $100^{\circ}\text{C} \sim 180^{\circ}\text{C}$ and for maximum 150 seconds.

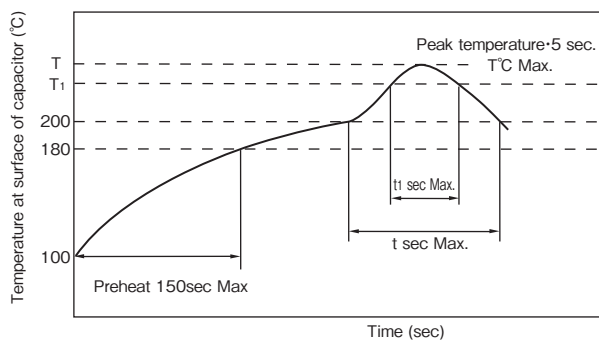

Series	Size	$T(^{\circ}\text{C})$ ①	$T_1(^{\circ}\text{C})$	$t(\text{sec})$ ②	$t_1(\text{sec})$ ③	Reflow cycle
SGV TLV	$\phi 12.5 \sim \phi 18$	240	230	60	30	1

- ① Peak temperature
- ② Time more than 200°C
- ③ Time more than T_1

※ Please contact us if the condition is over the maximum.

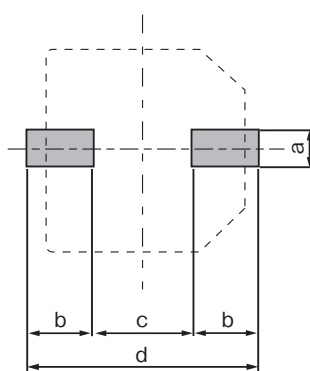
◆ RECOMMENDED LAND SIZE

Size	a	b	c	d
$\phi 4$	1.6	2.6	1.0	6.2
$\phi 5$	1.6	3.0	1.4	7.4
$\phi 6.3$	1.6	3.5	2.1	9.1
$\phi 8 \times 6.5$	1.6	4.5	2.1	11.1
$\phi 8 \times 10.5$	2.2	4.1	3.0	11.2
$\phi 10 \times 10.5$	2.2	4.3	4.5	13.1
$\phi 12.5$	2.5	6.0	5.0	17
$\phi 16$	3	6.5	8.0	21
$\phi 18$	3	7.5	8.0	23

◆ **Vibration proof packages with the supporting terminal**

- For chip Aluminum electrolytic capacitors more than case size ϕ 8, vibration proof packages supports.



◆ **PART NUMBER**

□□□ □□□ □□□□□ □ □□□ VB D×L
 Rated Voltage Series Rated Capacitance Capacitance Tolerance Option Vibration proof package No. Case Size

◆ **DIMENSIONS**

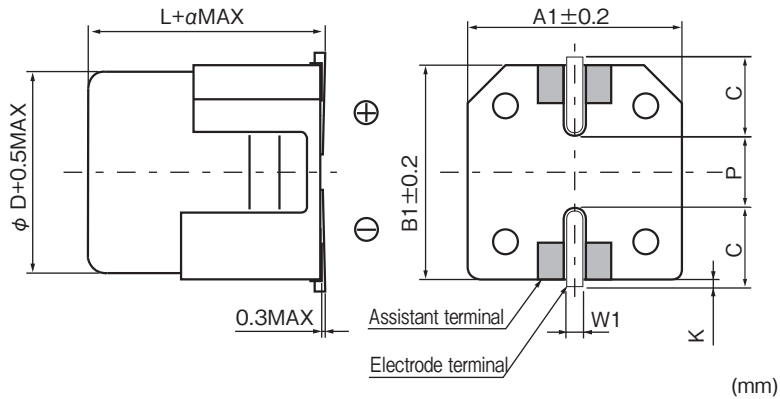

Size(ϕ D×L)	A1	B1	C	W1	P	K	α
8×10.5	8.3	8.3	3.1	0.9±0.2	3.1	0.5±0.4	0.5
10×10.5	10.3	10.3	3.4	0.9±0.2	4.5	0.5±0.4	0.5
12.5×13.5	13	13	4.9	1.1±0.3	4.5	0.7±0.4	1
12.5×16	13	13	4.9	1.1±0.3	4.5	0.7±0.4	1
16×16.5	17	17	6	1.1±0.3	6.8	0.7±0.4	1
16×21.5	17	17	6	1.1±0.3	6.8	0.7±0.4	1
18×16.5	19	19	7	1.1±0.3	6.8	0.7±0.4	1
18×21.5	19	19	7	1.1±0.3	6.8	0.7±0.4	1

◆ **RECOMMENDED LAND SIZE**

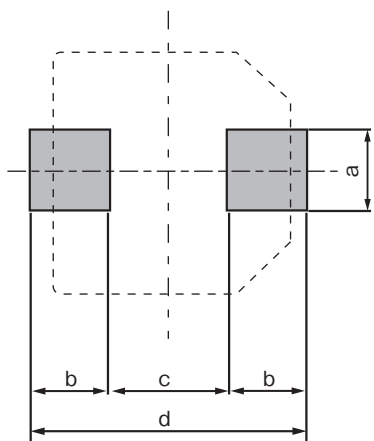

Size(ϕ D×L)	a	b	c	d
8×10.5	4.2	4.5	2.5	11.5
10×10.5	4.2	4.8	3.9	13.5
12.5	6.4	6.2	3.9	16.3
16	7	7.8	4.7	20.3
18	7	8.8	4.7	22.3